

	I	GB	D	F	E
ICW Ø 1 1/4" G	INGRESSO ACQUA REFRIGERATA	CHILLER WATER INLET	KALTWASSEREINGANG	ENTREE EAU GLACEE	ENTRADA AGUA ENFRIADA
UCW Ø 1 1/4" G	USCITA ACQUA REFRIGERATA	CHILLER WATER OUTLET	KALTWASSERRAUSGANG	SORTIE EAU GLACEE	SALIDA AGUA ENFRIADA
IHW Ø 3/4" G	INGRESSO ACQUA CALDA	HOT WATER INLET	WARMWASSEREINGANG	ENTREE EAU CHAUDE	ENTRADA AGUA CALIENTE
UHW Ø 3/4" G	USCITA ACQUA CALDA	HOT WATER OUTLET	WARMWASSERRAUSGANG	SORTIE EAU CHAUDE	SALIDA AGUA CALIENTE
IP	INGRESSO CAVO DI ALIMENTAZIONE	POWER SUPPLY CABLE INLET	SPEISEKABELINGANG	ENTREE CABLAGE D'ALIMENTATION	ENTREE CABLAGE ALIMENTATION
IS	INGRESSO USCITA SEGNALI	SIGNALS INLET / OUTLET	EINGANG / AUSGANG SIGNALE	ENTREE / SORTIE SIGNALES	ENTRADA / SALIDA SINALIZACIONES
IR	INGRESSO RETE	NETWORK INLET	NETWORKEINGANG	ENTREE RESEAU	ENTRADA RED
F Ø 6	INGRESSO ACQUA UMIDIFICATORE	HUMIDIFIER WATER INLET	WASSEREINGANG BEFEUCHTER	ENTREE EAU HUMIDIFICATEUR	ENTRADA AGUA HUMECTADOR
C-D Ø 32	SCARICO ACQUA UMIDIFICATORE E/O CONDENZA	HUMIDIFIER / CONDENSATE DRAIN CONNECTION	KONDENSAT - BZB. BEFEUCHTERAB - FLUSS	DECHARGE EAU HUMIDIFICATEUR ET/OU CONDENSEUR	DESCARGA AGUA HUMECTADOR Y/O CONDENSADOR
AR Ø 100	INGRESSO ARIA DI RINNOVO	FRESH AIR INLET	FRISHLUFTEINGANG	ENTREE AIR NEUF	ENTRADA AIRE DE RENOVU
I W 1" 1/4 GM	INGRESSO ACQUA CONDENSAZIONE	CONDENSING WATER INLET	WASSERGEKÜHLTER VERFLISSINGER-EIN	ENTREE EAU DE CONDESATION	SALIDA AGUA DE CONDENSACION
U W 1" 1/4 GM	USCITA ACQUA CONDENSAZIONE	CONDENSING WATER OUTLET	WASSERGEKÜHLTER VERFLISSINGER-AUS	SORTIE EAU DE CONDENSATION	SALIDA AGUA DE CONDENSACION

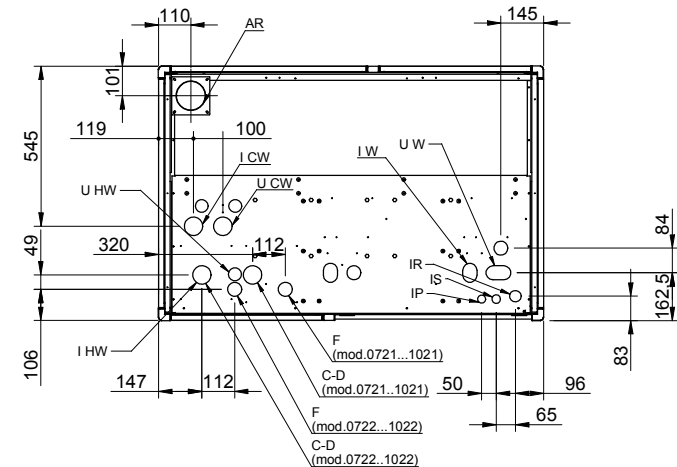

SEZIONE A-A

USCITA ARIA REFRIGERATA  
TREADED AIR DISCHARGE  
ZULUFTAUSGANG  
SORTIE AIR GLACEE  
SALIDA AIRE ENFRIADA

A AGGIORNATO DISEGNO		V. Tramontan		28/04/06	
REV.	Descrizione - Description	Disegnatore - Draftsman	Data - Date	Visto - Checked by	n' Com.
Materiale Material		Trattamento Treatment		Rif. Com.	
		Denominazione-Denomination <b>DISEGNO DI INSTALLAZIONE</b> INSTALLATION DRAWING		Series <b>TDE-W-D</b> Modello-Model <b>0721...1022</b>	
Scala-Scale	QUOTE SENZA INDICAZIONE DI TOLLERANZA <b>Grado di precisione medio</b> <b>UNI EN 22768-1(1996)</b>	Dis.-Draftsman <b>A.M.</b> Visto-Checked by	Foglio Sheet N. <b>1/1</b> Data-Date <b>17/10/2005</b>	Disegno-Drawing <b>DICI885X2A</b>	
				REV.	<b>A</b>